

BM50/60

Enhanced Performance



The perfect balance between efficiency and performance

This model is the ideal option when you need enhanced performance without compromising quality – more cups per day, and a wide range of beverages to choose from.

With the choice of a larger water tank to ensure uninterrupted service throughout the day, this machine is the perfect fit for workplace and retail environments.



- > Hopper Capacity – 750g
- > Screen Size – 7"
- > Plumbed/Tank (2L or 8L)
- > Silver or Gold
- > Power – 3kW
- > Drip tray plumbed or manual

Specification	BM50 & BM60
Recommended Daily Output	60+ Cups per day
Recommended Max Cup Size	12oz
Bean Hopper Capacity	750g
Decaf Function	Via grounds chute
Water Tank Capacity	2L (BM50) 8L (BM60)
Milk Supply	Via external cooler or bottle
Power Connection	230v / 2700w - 3100w
Dimensions (DxWxH)	559 x 304 x 572mm (BM50) 559 x 391 x 572mm (BM60)
Net Weight	18kg (BM50) 20kg (BM60)
Beverages	Espresso, Double Espresso, Americano, Cafe Creme, Cortado, Macchiato, Cafe Latte, Cappuccino, Flat White, Hot Milk, Hot Milk Foam, Hot Water
Screen Size	7 inch colour
Espresso Brewer Capacity	Up to 14g
Drip Tray Capacity	2L (or connect to mains drainage)
Grounds Waste Container Capacity	35 portions
Coffee Outlet (Height)	Adjustable 75mm -155mm
Thermoblock Quantity	Dual
Water Supply	Fixed water or internal tank

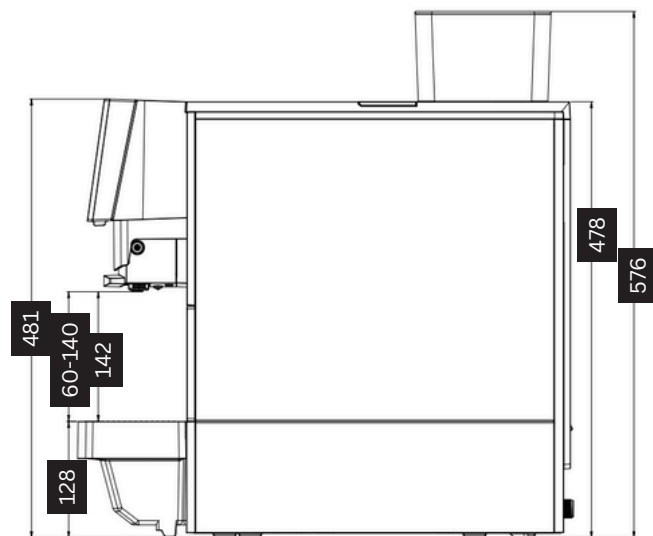
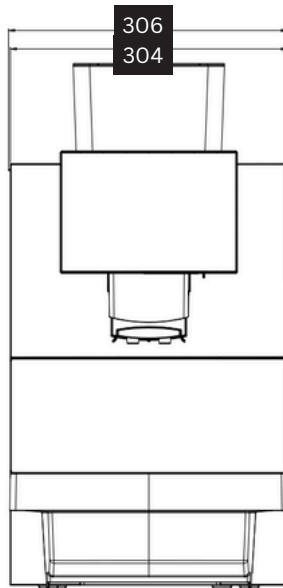
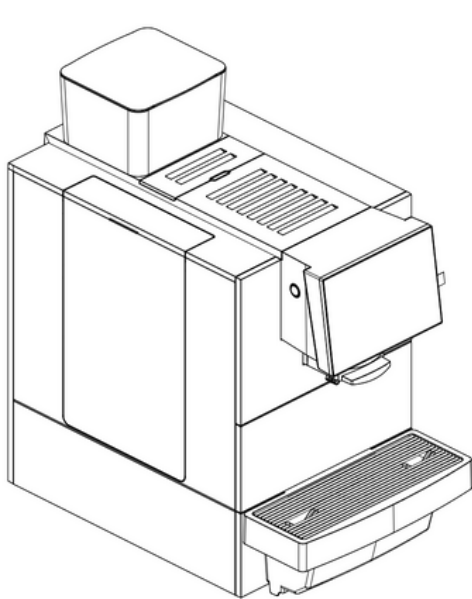

C2 COOLER
D291xW241xH361mm



C4 FRIDGE
D450xW220xH454mm



Options	
Colour Options	Silver or Gold
Built in Water Filter	Optional
Mains Water	Both Models
Mains Drainage	Optional
Knock Through Grounds	Optional
Accessories	Capacity
C4 Milk Fridge	4L
C2 Milk Cooler	2L