

## BM80/100

*Effortless Perfection*



### The BM80/100 is an excellent choice for busier environments

With the ability to amend pour sequencing to improve speed of service, this machine really is the ultimate solution for any setting. Customisable menu choices enable the user to create their own, personalised drink options that can be accessed at the touch of a button. A reliable, high-performance and energy efficient machine for truly effortless perfection.



- > Hopper Capacity – 1kg
- > Screen Size – 10"
- > Plumbed/Tank (2L or 8L)
- > Silver
- > Power – 3kW
- > Drip tray plumbed or manual

Specification	BM80 & BM100
Recommended Daily Output	100+ Cups per day
Recommended Max Cup Size	16oz
Bean Hopper Capacity	1000g
Decaf Function	Via grounds chute
Water Tank Capacity	2L (BM80) 8L (BM100)
Milk Supply	Via external cooler or bottle
Power Connection	230v / 2700w - 3100w
Dimensions (DxWxH)	559 x 304 x 628mm (BM80) 559 x 391 x 628mm (BM100)
Net Weight	18.8kg (BM80) 20.8kg (BM100)
Beverages	Espresso, Double Espresso, Ristretto, Americano, Cafe Creme, Cortado, Macchiato, Cafe Latte, Cappuccino, Flat White, Hot Milk, Hot Milk Foam, Hot Water
Screen Size	10 inch colour
Espresso Brewer Capacity	Up to 14g
Drip Tray Capacity	2L (or connect to mains drainage)
Grounds Waste Container Capacity	35 portions
Coffee Outlet (Height)	Adjustable 75mm -155mm
Thermoblock Quantity	Dual
Water Supply	Fixed water or internal tank

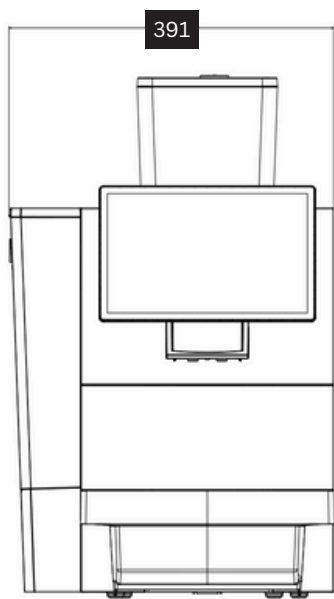

**BM80**

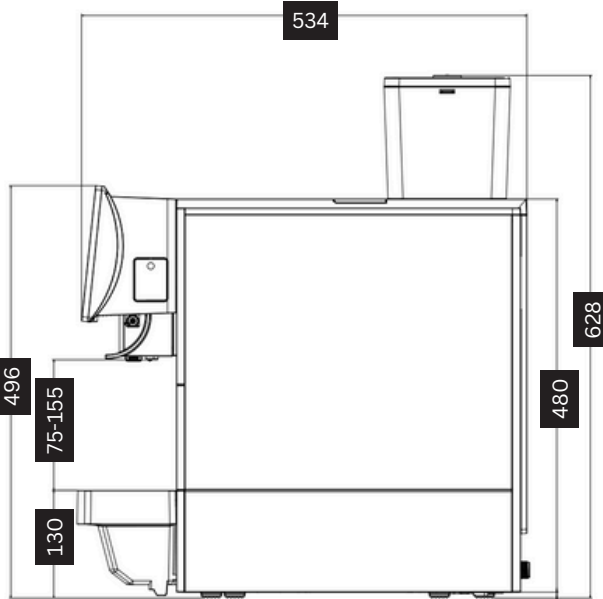

**BM100**

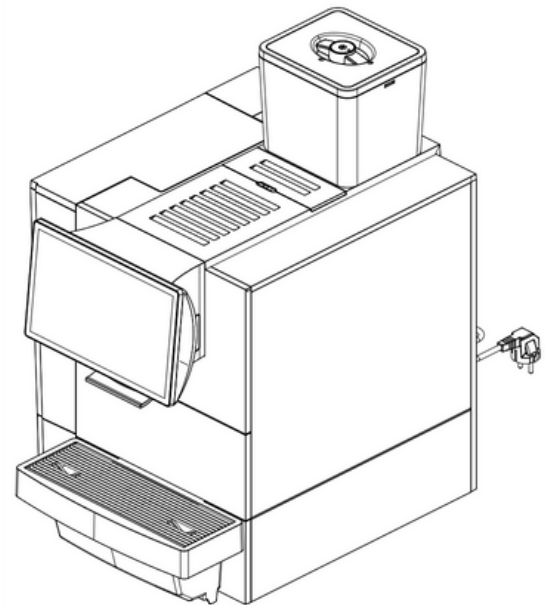

**C2 COOLER**

D291xW241xH361mm

**C4 FRIDGE**

D450xW220xH454mm



Options	
Colour Options	Silver
Built in Water Filter	Optional
Mains Water	Both Models
Mains Drainage	Optional
Knock Through Grounds	Optional
Accessories	Capacity
C4 Milk Fridge	4L
C2 Milk Cooler	2L

